

TARGET WATERFALL TOPPING APPLICATOR

Quantum's MLT2000 Multi-Lane Target Waterfall Topping Applicator deposits a variety of toppings such as cheese, IQF vegetables and meats onto product at speeds up to 60 feet per minute, per lane. The MLT2000's no tray, no fill capability reduces waste, increases productivity and ensures consistent coverage. Portable and compact, the MLT2000 can cantilever over existing lines.



MODEL #MLT2000

SPECIFICATIONS

PRODUCT:

Portion and Apply Product to Prepared Tray Meals, Bowls, Flatbreads, and Similar Products

AVAILABLE WIDTHS:

Standard Machines on 8-1/4", 10-1/4", and 12" Lane Centers
Cantilevers Over Existing Conveyors Up To 24" Wide
Other Lane Centers Optional

PRODUCTION RATE:

Up To 60 Feet Per Minute

UTILITY REQUIREMENTS:

240 Volts, 3 Phase, 60 Amp, 60 Hz
Other Voltages Optional

OPTIONS:

Left or Right Hand Cantilever
Flat Belt Product Conveyor
Production Line Integration
Reclaim Conveyor System
Hopper Feed Conveyor
Bulk Feed Conveyor
Hopper Diverter

FEATURES:

- ✓ No Tray/No Fill Over Two Lanes
- ✓ Two Independent Product Belts
- ✓ Cantilevered Belt
- ✓ Independent Servomotor Driven Top Belts
- ✓ Independent Servomotor Flinger Shutoffs
- ✓ Photo Eyes and Mounts
- ✓ One (Target) Product Funnel Included Per Lane
- ✓ Hand Crank Rake Height Adjustment
- ✓ Simple Flinger Height and Speed Adjustment
- ✓ Gull Wing Safety Guards with Interlocks
- ✓ 20 User Defined Recipes
- ✓ Large Color Touch Screen
- ✓ Swing Away Control Box Allows Easy Access To Motors and Bearings
- ✓ Adjustable Height Funnels
- ✓ Stainless Steel Frame
- ✓ Stack Light Indicates Machine Status
- ✓ USDA Compliant Construction
- ✓ UL508A Controls
- ✓ Independent Hopper Level Sensors
- ✓ Solid Round Bar Construction with Minimal Flat Surfaces
- ✓ Locking Swivel Casters with No Exposed Threads
- ✓ Wash Down Capable
- ✓ No Tools Required for Sanitation



WWW.Q-T-S.COM

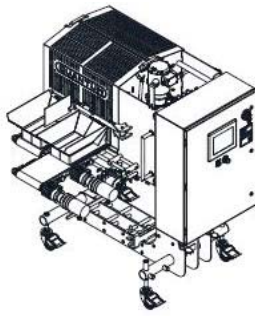
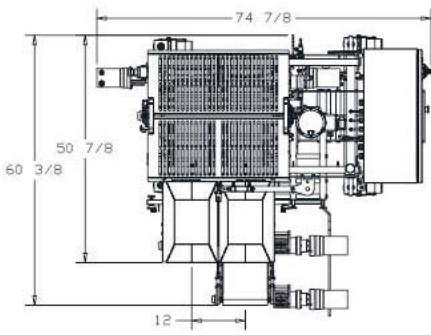

7" Color Touch Screen



Hand Crank Rake Height Adjustment

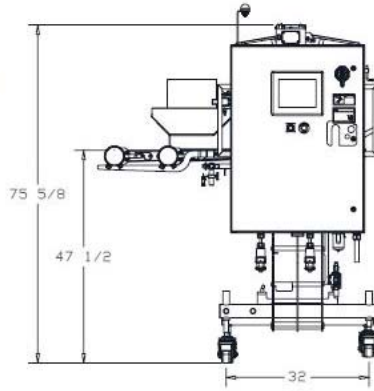
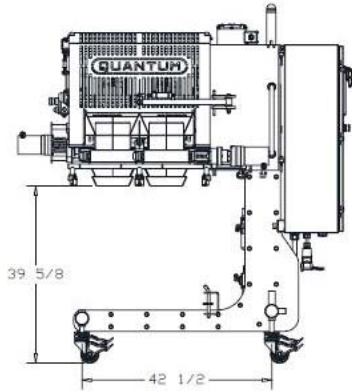

Hopper Feed Diverter



No Exposed Threads
Locking Swivel Casters



Two Independent Lanes



Open Gull Wings
Easy Access for Sanitation



* Shown with optional Hopper Feed Conveyor and Bulk Feed Conveyor

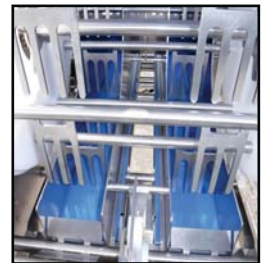

Flinger Height Adjustment

**QUANTUM MANUFACTURES HIGH SPEED
AUTOMATED TOPPING EQUIPMENT. WE OFFER
STANDARD PRODUCTION SYSTEMS AS WELL
AS CUSTOM ENGINEERED SOLUTIONS.**

CONTACT US: +1 815.464.1540

INFO@Q-T-S.COM | WWW.Q-T-S.COM