

FLAT BELT COMPRESSION CONVEYING SYSTEM

The Quantum Compression Conveying System is fully adjustable and will compress ingredients to allow a more uniform thickness. All Quantum conveying systems feature stainless steel construction and utilize USDA compliant, reinforced, urethane belting. Sanitary design with no tools needed for disassembly minimizes cleaning time. Custom lengths and widths are available.



MODEL #QTCC SERIES

SPECIFICATIONS

BELTS:

USDA Compliant
V-guide for Easy Tracking

UTILITY REQUIREMENTS:

380-480 VAC., 15 Amp Circuit 50-60 Hz.
Emergency Stop Circuit
Other Voltages Available

PRODUCTION RATES:

Up to 100 Feet Per Minute

OPTIONS:

Side Of Line Reclaim Conveyor

FEATURES:

- ✓ Cantilevered Design
- ✓ Center Driven Belt
- ✓ Blade Style UHMW Belt Scraper
- ✓ Adjustable Conveyor Ends
- ✓ Gull Wing Safety Guards with Interlocks
- ✓ Heavy Duty Stainless Steel Construction
- ✓ Variable Speed
- ✓ Continuous Sanitary Welds
- ✓ Wash Down Capable
- ✓ No Touch Required For Sanitation
- ✓ Adjustable Stainless Steel Feet,
No Exposed Threads



QUANTUM®

WWW.Q-T-S.COM

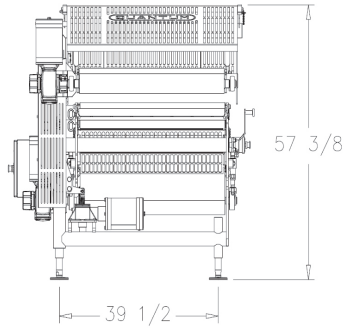
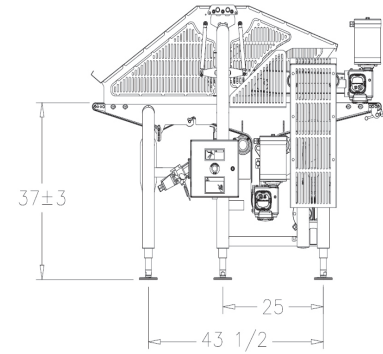
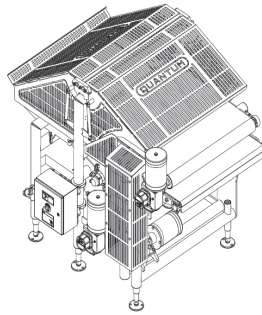
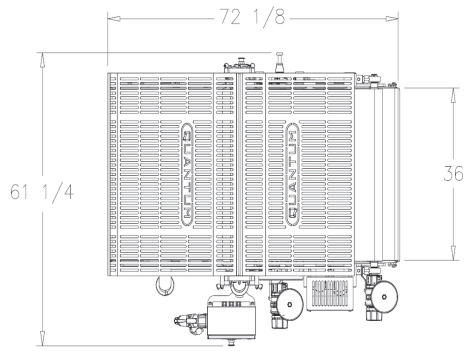

UHMW Belt Scraper

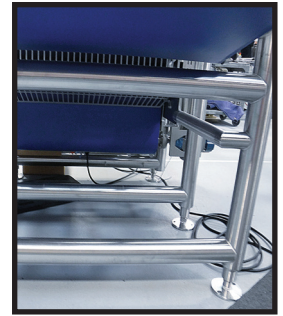

Solid Round Bar Construction With Minimal Flat Surfaces

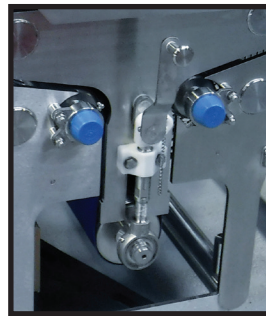

Easy Belt Tensioning

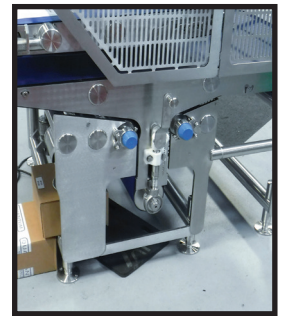

Center Drive Conveyor



Adjustable Feet With No Exposed Threads

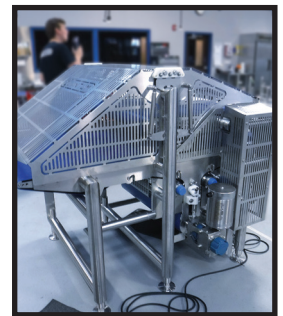

Machine Guarding With Interlocks

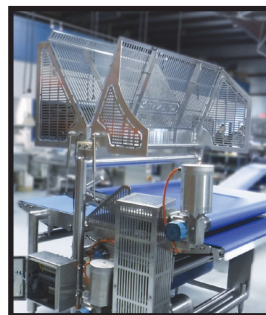

Gull Wing Guarding With Interlocks



Optional Side Of Line Reclaim Conveyor



QUANTUM[®]

CONTACT US: +1 815.464.1540
 INFO@Q-T-S.COM | WWW.Q-T-S.COM
 U.S.A.

PORTION & APPLY

TOP IT | FILL IT | SLICE IT