

# CONVEYORIZED TOPPING APPLICATOR

Quantum's WA1000 Conveyorized Topping Applicator is capable of evenly applying a variety of toppings to your products. The WA1000, with optional Reclaim Conveyor System is a durable and easy to use system.



\*Shown  
With Options

MODEL #WA1000

## SPECIFICATIONS

### PRODUCT:

Cheeses, IQF Vegetables, IQF Meats, Nuts, Streusel & More

### AVAILABLE WIDTHS:

Up to 48" Usable Deposit Width

### PRODUCTION RATE:

Up to 100' of Product per Minute

### UTILITY REQUIREMENTS:

200-240 VAC., 3 Phase 28 Amp 50/60 Hz.  
380-480 VAC., 3 Phase 17 Amp 50/60 Hz.  
Other Voltages Optional

### CONVEYOR:

Cantilevered Design  
Stainless Steel Construction  
Polyurethane Belting

### OPTIONS:

Reclaim Conveyor System  
Bulk Feed Conveyor  
Targeted Depositing  
Catch Trays

### FEATURES:

- ✓ Heavy Duty Stainless Steel Frame
- ✓ Rake Height Adjustment
- ✓ Adjustable Product Flinger
- ✓ Center Driven Product Belt
- ✓ Hopper Level Sensing And Auto Fill
- ✓ Hopper Product Diverter
- ✓ Adjustable Infeed And Outfeed Conveyor Ends
- ✓ Drop Down Conveyor Ends For Easy Belt Removal
- ✓ Hinged Rake Guard Lifts Up For Sanitation
- ✓ Stainless Steel Bearing Housings
- ✓ Sanitary Leveling Feet With No Exposed Threads
- ✓ Easily Adapts To An Existing Topping Line
- ✓ Open, Easy To Clean, Sanitary Design, Wash Down Capable
- ✓ Continuous Sanitary Welds
- ✓ Adjustable Stainless Steel Feet, No Exposed Threads



WWW.Q-T-S.COM

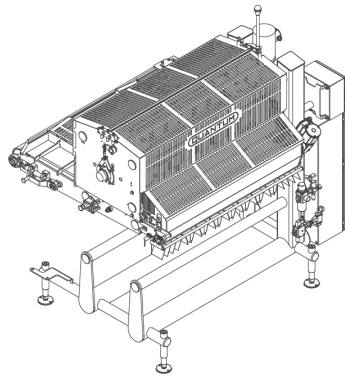
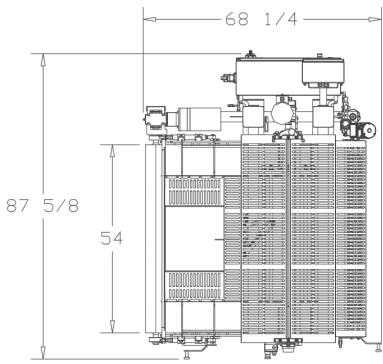

Adjustable Stainless Steel Feet, No Exposed Threads



UHMW Belt Scraper

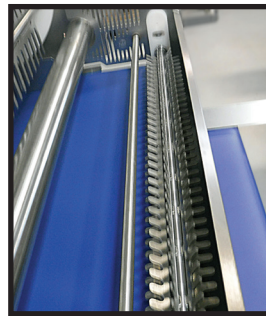
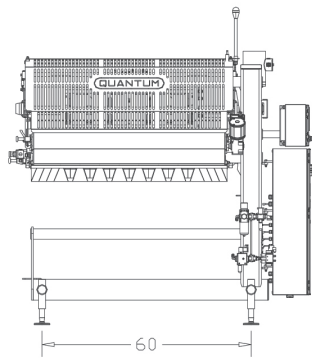
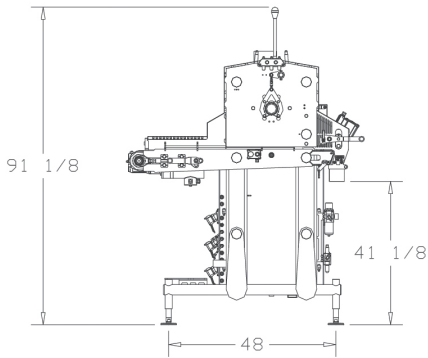

Adjustable Flinger

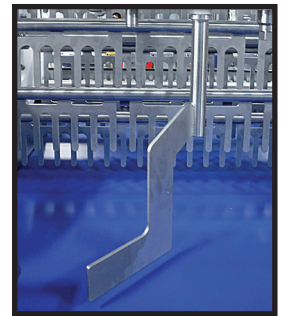

Hopper Diverter



No Tool Belt Removal



Gull Wing Safety Guards with Interlocks



Optional Reclaim Conveyors



Optional Bulk Feed



CONTACT US: +1 815.464.1540  
 INFO@Q-T-S.COM | WWW.Q-T-S.COM  
 U.S.A.

**PORTION & APPLY**

TOP IT | FILL IT | SLICE IT